

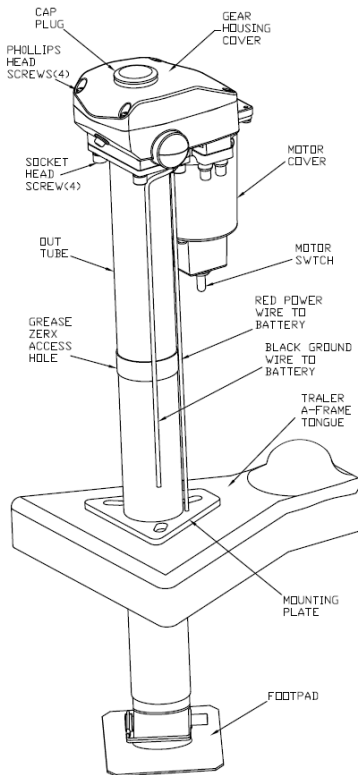

## INSTALLATION/OPERATION



### APPLICATION

The Ultra 3502 Electric Tongue Jack is a 12-volt motor-driven screw jack for use on travel trailers and boat trailers.

### SPECIFICATIONS

Vertical Load: **3500** lbs. continuous over full stroke with 5000 lbs. instantaneous tongue breakaway capacity.

Travel – 18"

Power Requirement -12-volt D.C.

Model # 3502 - 2" outer tube w/ 1<sup>3</sup>/<sub>4</sub>" inner tube

Retracted Height - 25<sup>1</sup>/<sub>2</sub>"

Removable Foot Pad -5 1/2 "

Approximate Shipping Weight – 22 lbs.

### INSTALLATION

1. Block the wheels and support the trailer "A" frame securely.
2. Remove the existing jack.

**WARNING: Failure to block trailer wheels securely could result in personal injury and possibly death.**

**NOTE: Save the original nuts, bolts, and washers for installing the Ultra 3502 Electric Tongue Jack.**

3. Install the Electric Tongue Jack using original nuts and bolts. Align the motor head so that the motor housing is facing the front of the "A" frame.
4. The Electric Tongue Jack was designed to replace an existing

manual jack. The diameter of the outer tube of your chosen jack, will need to match the existing hole size, or you will need to modify the hole diameter to fit.

5. Connect the red positive lead to the positive terminal of the battery. Connect the black ground wire to negative terminal of the battery.

**WARNING: When using an extension wire, DO-NOT use smaller than #10-gauge wire.**

**CAUTION: We do not recommend using the flip-up type footpad. Doing so requires the tongue jack to be altered which voids the warranty and can cause the failure of the jack.**

### OPERATION

1. Block trailer wheels securely at all times when operating the jack.

**WARNING: Failure to block trailer wheels securely could result in personal injury and possibly death.**

2. The Ultra 3502 Electric Tongue Jack is operated by means of the Toggle Switch located under the motor housing.
3. Extend the jack by holding the Toggle Switch in the Extend position.

**CAUTION: The motor will stall if jack reaches the full extent of travel both in retract and extend directions. There is an over load protection for the jack to shut off power that will auto reset in 15 seconds. After using jack, operator should learn the travel limit stops. The operator should stop the jack before reaching the travel limit.**

4. Retract the jack by holding the Toggle Switch in the Retract position. The jack is now fully retracted.

**NOTE: If the motor should stall with the jack in the fully retracted position, and the Toggle Switch is not released, the motor will automatically switch off.**

### MANUAL OPERATION

1. Remove plug cap in the access hole. (located top center of the housing cover)
2. Insert the 11mm deep well socket (included) in the access hole, over the drive spindle tang. Rotate the socket clockwise to retract and counter clockwise extend.
3. When complete, remove socket and replace plug cap.

### LUBRICATION

The jack is lubricated before leaving the factory. Under normal conditions, lubrication will be needed annually.

1. Grease the Jackscrew by extending the jack until the grease fitting is aligned with the hole in the outer tube. Using a standard grease gun and standard chassis lube, give two pumps.
2. Grease the gears in gearbox.
  - A. Remove the gear cover via 4 Phillips screws.
  - B. Grease the gears with chassis lube and reinstall cover.

### STORAGE

A hook and loop strap has been included to help store the wire/connector to the jack when not use.



57985 State Road 19, South  
 Elkhart, Indiana 46517  
 PH: (800) 860-7571  
 FX: (800) 860-4880  
 www.ultra-fab.com

**ULTRA 3502 ELECTRIC TONGUE JACK**  
**P/N 38-944017**  
 US PATENT 9,821,774 B1

## MOTOR EXPLODED VIEW

No.	Part No.	Description	Q'ty
1	38-760001	GEAR HOUSING BASE	1
2	38-760002	BUSHING 16	1
3	38-760003	BUSHING 9.5	2
4	38-760004	COLLAR HEX HEAD	1
5	38-760005	THURST BEARING	1
6	38-760006	SPUR GEAR	1
7	38-760007	MAIN GEAR	1
8	38-760008	PINION GEAR 12T	1
9	38-760009	PIN 6X18	1
10	38-760010	PIN 3X14	1
11	38-760011	GEAR HOUSING COVER	1
12	38-760012	RUBBER PLUG	1
13	38-760013	LIGHT SWITCH	1
14	38-751152	M5	2
15	38-760015	GROMMET	1
16	38-760016	SNAP RING	1
17	38-760017	LIGHT	2
18	38-760018	MOTOR	1
19	38-760019	MOTOR HOUSING	1
20	38-760020	SWITCH HOUSING	1
21	38-760021	CIRCUIT BREAKER	1
22	38-760022	MOTOR SWITCH	1
23	38-760023	SWITCH BOOT	1
24	38-760024	LOCK WASHER M4.1	4
25	38-751010	SCREW M4X12	14
	<b>NOT SHOWN</b>		
	38-760025	SOCKET 11MM DEEP WELL MANUAL OVERRIDE	1

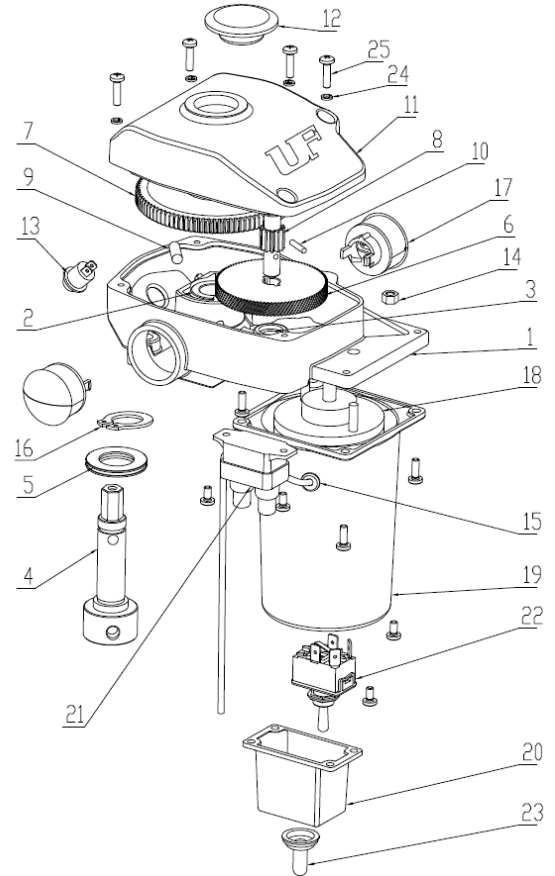



## LOWER STEM ASSEMBLY EXPLODED VIEW

No.	Part No.	Description	Q'ty
1	38-760102	TUBE OUTER 2"	1
2	38-114452	SERRATED WASHER 8	4
3	38-760103	WASHER M8	4
4	38-760104	BOLT M8x25	4
5	33-760105	RUBBER BAND	1
6	38-760107	FOOTPAD STD 2"	1
7	38-141023	WIRE LOCK PIN	1
8(A-E)	38-760113	TUBE INNER 1.75" ASSY	1
8A	38-760004	COLLAR HEX HEAD	1
8B	38-760109	RETAINING PIN	1
8C	33-760005	THRUST BEARING	1
8D	17-753230	GREASE ZERK 6-1.0mm	1
8E	33-760115	TUBE INNER 1.75"	1
9	38-751127	UPPER PIN	1
10	38-760111	COTTER PIN	1

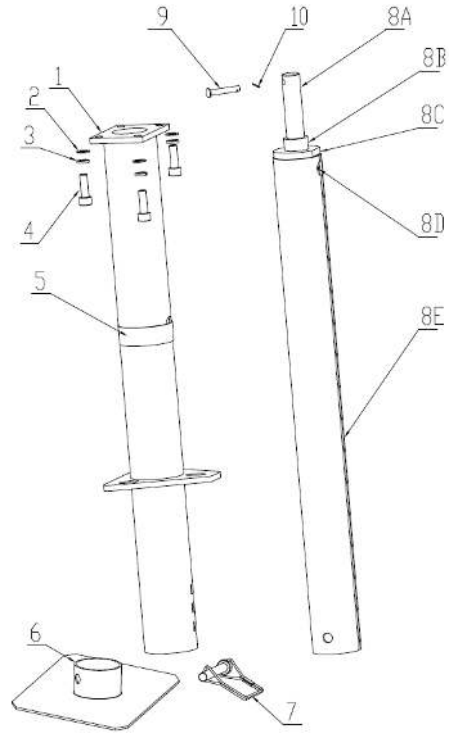

### NOT SHOWN:

**38-760114 LOWER STEM ASSEMBLY (INCLUDES 38-760102 AND 38-760113)**



### WIRING DIAGRAM

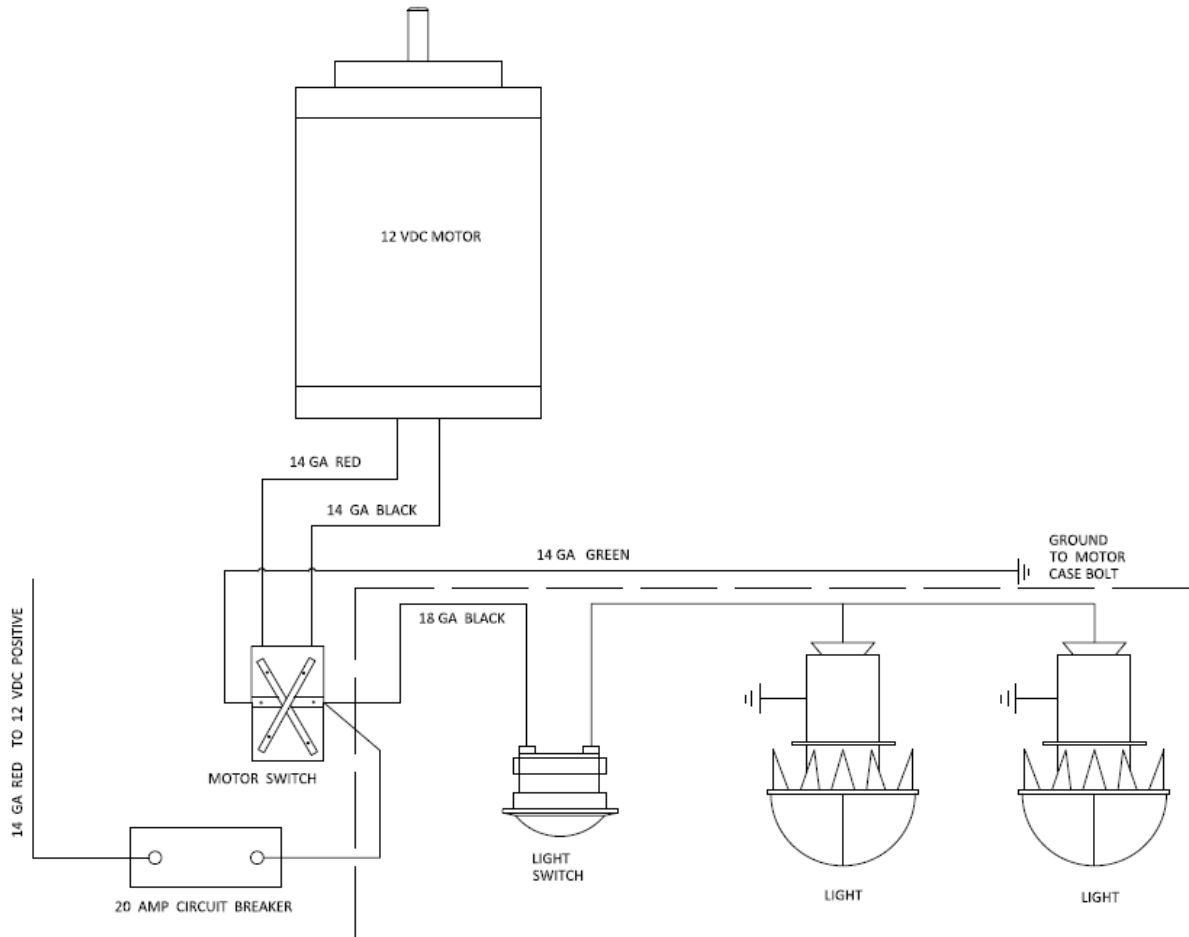



57985 State Road 19, South  
Elkhart, Indiana 46517  
PH: (800) 860-7571  
FX: (800) 860-4980  
www.ultra-fab.com

ULTRA 3502 ELECTRIC TONGUE JACK  
P/N 38-944017  
US PATENT 9,821,774 B1

## TWO-YEAR LIMITED WARRANTY ULTRA 3502/3502-7/4000/4002 TONGUE JACKS

### THE MANUFACTURER NAMED BELOW MAKES THE FOLLOWING WARRANTY WITH RESPECT TO THE ABOVE ULTRA-FAB PRODUCTS

1. This Warranty is made only to the first Purchaser (hereinafter called the "Original Purchaser") who acquires this product for their own use.
2. This Warranty will be in effect for two years from the date of purchase by the Original Purchaser. It is suggested that the Original Purchaser retain a copy of the dated bill of sale as proof of the date of purchase.
3. This Warranty covers only specified parts which shall be free from defects in material and workmanship under normal use. This Warranty does not cover conditions unrelated to the material and workmanship of the product. Such unrelated conditions include, but are not limited to (a) faulty installation and any damage resulting from such; (b) the need for normal maintenance and any damage resulting from the failure to provide such maintenance; (c) failure to follow Manufacturer's instructions for use of this product, and (d) any accident to, or misuse of, any part of this product and any alteration by anyone other than the Manufacturer or its authorized representative.
4. In order to obtain the benefits of this Warranty, you should return the product which you find defective to the Manufacturer named below during the period that this Warranty is in effect. All charges incurred in delivery of the product to the Manufacturer, and in picking it up after the Warranty service has been completed, must be paid by the Original Purchaser.
5. Any item returned in the manner described in paragraph 4 will be examined by the Manufacturer. If it is found that the returned item was defective in material or workmanship, the Manufacturer will repair it without charge for material and labor.
6. Ultra-Fab will pay freight on replacement parts during the first 90 days of ownership by the Original Purchaser.
7. The Manufacturer does not authorize any person or company to create any Warranty obligation or liability on their behalf.
8. IN NO EVENT SHALL THE MANUFACTURER BE LIABLE FOR INCIDENTAL OR CONSEQUENTIAL DAMAGES. SOME STATES DO NOT ALLOW THE EXCLUSION OR LIMITATION OF INCIDENTAL OR CONSEQUENTIAL DAMAGES SO THE ABOVE LIMITATION OR EXCLUSION MAY NOT APPLY TO YOU.
9. ANY IMPLIED WARRANTY, INCLUDING THE IMPLIED WARRANTY OF MERCHANTABILITY AND FITNESS FOR ANY PURPOSE, IS LIMITED TO THE DURATION OF THIS LIMITED WARRANTY. SOME STATES DO NOT ALLOW LIMITATIONS ON HOW LONG AN IMPLIED WARRANTY LASTS, SO THE ABOVE LIMITATION MAY NOT APPLY TO YOU.
10. THIS WARRANTY GIVES YOU SPECIFIC LEGAL RIGHTS, AND YOU MAY ALSO HAVE OTHER RIGHTS WHICH VARY FROM STATE TO STATE.

## Ultra-Fab Products, Inc.

57985 SR 19 S., Elkhart, IN 46517  
Tel: (574) 294-7571 Fax: (574) 294-4980  
[www.ultra-fab.com](http://www.ultra-fab.com)



# WARRANTY REGISTRATION

Please visit our website [www.ultra-fab.com](http://www.ultra-fab.com)  
click on the **WARRANTY** tab and **REGISTER**  
**YOUR WARRANTY.**

If you register your tongue jack within 90  
days of purchase your warranty is extended  
from 2-years to 5-years.

