



85-4609 rev. 06 04-26



Installation Instructions

Polyurethane Bushing Kit for Ford F-53 (Rear) (replaces OE bushings and brackets)

part #4139-300
1-3/8" diameter



INTRODUCTION

Thank you for purchasing this polyurethane bushing kit. This kit is designed to improve the handling characteristics of your Ford F-53 by reducing the body roll and balancing the weight transfer during cornering. The bushing kit is engineered for long life and trouble-free performance. For maximum suspension control, use this kit along with our auxiliary anti-sway bar kit.

All the hardware needed for installation is included in this kit. Refer to the PARTS LIST in these instructions to identify the parts.

SUGGESTED TOOLS

The following tools are suggested to complete the installation procedures:

- Metric wrenches
- Metric sockets
- Socket wrench
- Vise
- Cylinder smaller than 1-5/8" diameter (Step 3)
- Cylinder larger than 1-5/8" diameter (Step 4)

WARNING

Failure to follow these instructions can result in property damage, personal injury or even death.

- If raising the vehicle to install the anti-sway bar, always support the vehicle with jack stands at both frame rails or at the rear axle before working underneath. Ensure that the jack stands are securely positioned, and are rated at or above the weight of the vehicle.
- The installer must read the instructions and use all bolts and parts supplied. Use only the parts supplied by ROADMASTER to install this kit.
- Minor modifications are sometimes necessary due to slight vehicle variations, even for the same year, make and model.
- Regardless of year, make and model, a wide range of options for specific applications may or may not interfere with the installation. It is the installer's responsibility to make certain that equipment is not damaged once the suspension solution travels through the full range of motion. Failure to ensure adequate clearance could result in non-warranty property damage, personal injury or even death.
- If running changes were made by the manufacturer after this kit was designed, there may be weldments, braces, gussets, or other structural items which interfere with the installation. It is the installer's responsibility to allow for these running changes without sacrificing the structural integrity of the anti-sway bar. Failure to securely fasten the anti-sway bar could result in property damage, personal injury or even death.
- ROADMASTER will not be responsible for any damage or injury resulting from any modification or alteration.
- Check ALL the fasteners for tightness before and after road testing the vehicle.
- Do not use this document for custom fabrication, as it may not show all parts or structural components.
- Do not use an air impact wrench when re-installing bolts, as stripped threads may result.
- This anti-sway bar is only warranted for the original installation. Installing a used anti-sway bar on another vehicle is not recommended and will void the warranty.

PARTS LIST

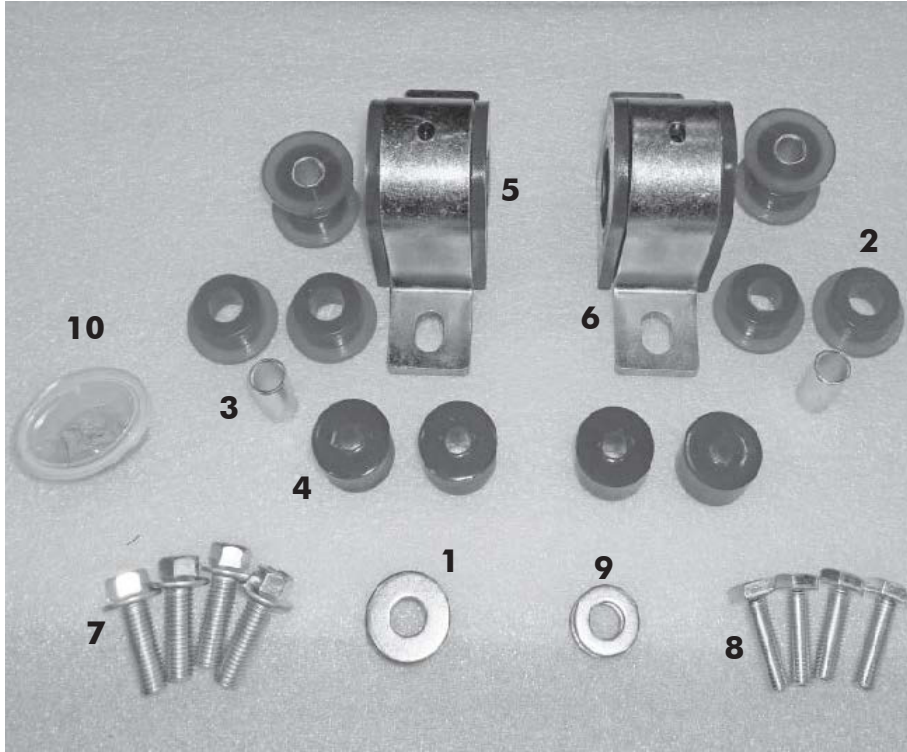

This drawing is for assembly information only

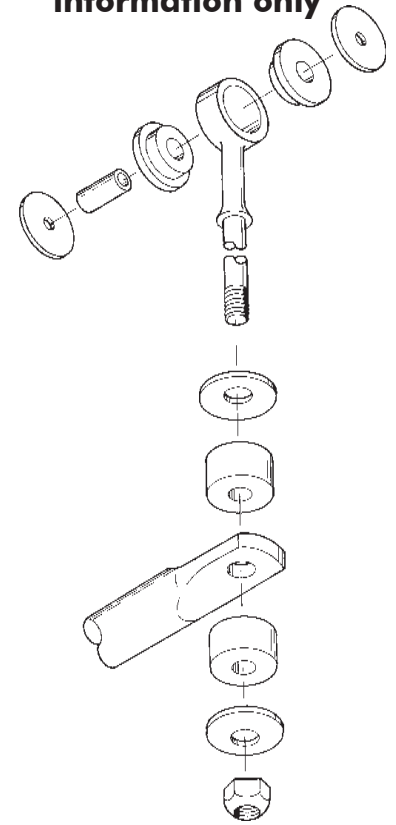

Part #4139-300

Part #	Description	Qty	Part #	Description	Qty
1.	350308-00 Washer, 1/2" large o.d	4	6.	B141 Bracket, saddle	2
2.	205223-50 Bushing, poly hat	8	7.	357200-20 Bolt, 12mm	4
3.	205522-00 Sleeve, spacer	4	8.	356102-00 Bolt, 10mm	4
4.	205381-00 Poly bushing	4	9.	350308-20 Washer	4
5.	205219-10 Bushing, split	2	10.	400011-30 Aqualube Grease	1

INSTALLATION

The following instructions must be followed in the order listed to ensure a proper installation and to preserve the ROADMASTER warranty.

Note: Due to the variety of endlinks that Ford has used through the production of this chassis, some endlink parts may not be required from this kit. Before disassembling or removing the bushings from the factory endlink, ensure that the factory bushings match the polyurethane bushings included in this kit. If the diameters do not match, keep the factory endlink intact and do not use the included bushings for the endlinks in this kit.

Support vehicle and remove the wheels (Steps 1 and 2 are optional, for working room)

1. Unload the suspension.

Before beginning this installation, unload the suspension to allow safe access to the underside of the vehicle. You can use a hoist or jack stands to accomplish this.

2. Put jack stands under the frame.

Place the jack stands under the rear axle housing to correctly locate the mounting points for the links. Lower the axle housing onto the jack stands. Push the side of the body to make sure that the vehicle is stable.

⚠ WARNING

If raising the vehicle to install the kit, always support the vehicle with jack stands at both frame rails or at the rear axle before working underneath. Ensure that the jack stands are securely positioned, and are rated at or above the weight of the vehicle.

3. Remove the factory anti-sway bar bushings.

4. Remove the saddle brackets and bushings.

Use the 13mm wrench and socket to remove the bolts from each saddle bracket. Remove the saddle bracket assemblies from the vehicle (Figure 1). Slide the bushings over or cut them off with a knife.

CAUTION

Do not allow the anti-sway bar to hit the driveshaft, or it may damage the driveshaft. Damage to the driveshaft may result in unwanted vibration while driving the vehicle.

5. Install the saddle bushings and brackets on the vehicle.

Lubricate inside of the split bushing with the grease provided (Figure 2). Install bushing on sway bar and slide saddle bracket over bushings.

6. Install bolts in the saddle brackets.

Use either 10mm or 12mm bolts depending on which size bolts were removed. Washer (W421) may be needed to allow bolt to install fully (check to see if bolt touches axle tube).

Figure 1

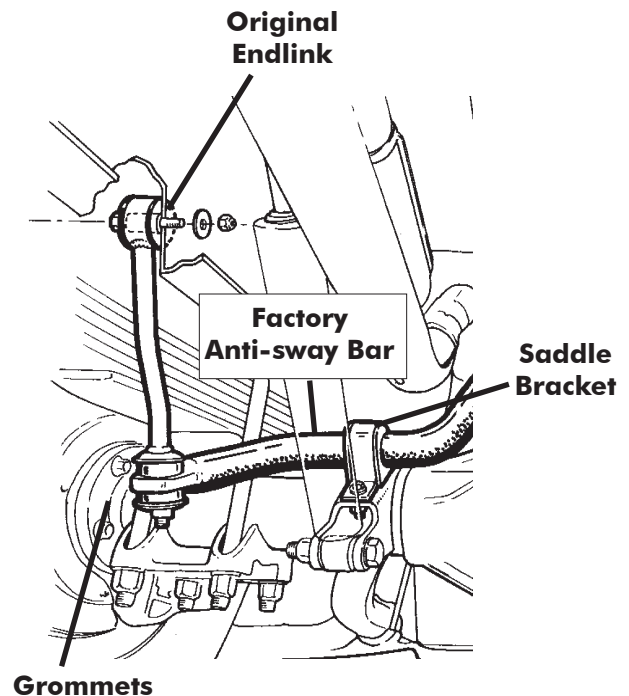
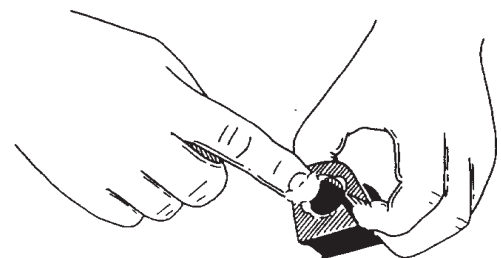

Figure 2



INSTALLATION

7. Remove the bar from the endlinks.

Use the 15mm wrench to remove the nuts from the end of the links. Support the anti-sway bar end as you remove the nut from the second endlink.

WARNING

Removing the endlinks will release the anti-sway bar. The anti-sway bar is heavy, and may cause property damage or personal injury if it falls on equipment, engine components or any part of your body. Ensure that the anti-sway bar is supported and that you are out of the way when removing the brackets.

Failure to follow these instructions may cause property damage, personal injury or even death.

8. Remove the endlinks.

Use a socket and wrench to remove the bolts and nut that hold each endlink to the vehicle frame. Note: due to manufacturing variances, some applications may need one horizontal and one vertical endlink pieces. If this is the case, not all pieces of this kit will be used.

9. Replace the bushings in the endlinks.

10. Remove the original bushings.

Find a socket or other cylinder that has a slightly larger ID than the endlink and another that has a slightly smaller OD than the bushing. Hold the link and sockets with a large vise so the small socket will push the bushing into the large socket. Tighten the vise to remove the bushing.

11. Install the bushings into the endlinks.

Insert one bushing into the endlink. Push the sleeve into the bushing until it reaches the side with the flange. Push the other bushing into the link (Figure 3).

12. Connect the endlinks to the anti-sway bar.

Install the original washer and a grommet on the endlink. Install the endlink assembly on the end of the anti-sway bar so that the grommet is on the top side of the anti-sway bar end. Install another grommet and an original washer and start the nut. Install the grommets, washer and endlink for the other end of the anti-sway bar. Do not tighten the nuts (Figure 4).

WARNING

Over-tightening the grommets may cause premature failure of the grommets and/or the endlinks. If the grommets fail, the bushing kit will not stabilize the vehicle at full capacity, which may cause reduced cornering ability or other reductions in vehicle handling or performance. Failure to follow these instructions may result in property damage, personal injury or even death.

13. Re-attach the endlinks to the frame.

Figure 3

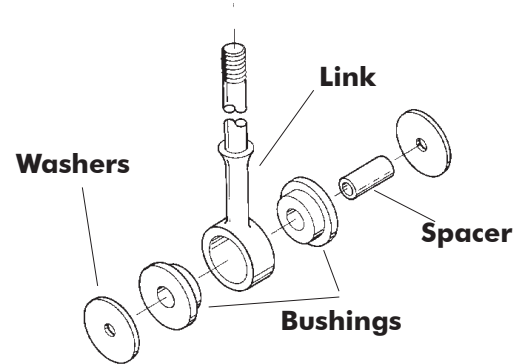
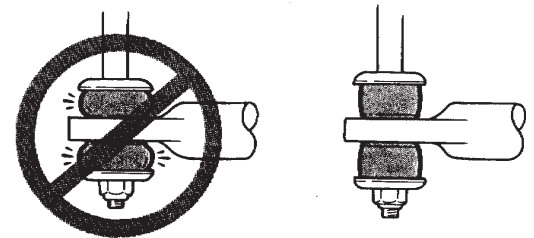

Figure 4



INSTALLATION

14. Check the anti-sway bar and tighten fasteners.

Make sure the anti-sway bar is centered, side-to-side. Tighten fasteners but do not over-tighten grommets.

15. Replace the wheels and road test the vehicle.



WARNING

After road testing, re-check all fasteners for proper tightness — if a fastener has worked loose or fallen off, re-tighten or replace it. Without all kit components properly tightened or in place, the bushing kit will not stabilize the vehicle at full capacity, which may cause reduced cornering ability or other reductions in vehicle handling or performance.

Failure to follow these instructions may result in property damage, personal injury or even death.