



856080-04 01.21

# Smart Diode Wiring Kit for variable voltage vehicles with incandescent bulbs part number 153782

All specifications are subject to change without notice.

ROADMASTER, Inc. 6110 NE 127th Ave. Vancouver, WA 98682 800-669-9690 Fax: 360-735-9300 www.roadmasterinc.com

## Parts

- (1) 4-wire wiring harness, 27 feet in length
- (2) white wires, 1 foot in length
- (2) Smart Diodes for incandescent bulbs
- (1) 10-12 gauge butt connector (yellow)
- (3) ring terminals
- (1) 3-foot length of split loom (11) wire ties
- (3) Tek screws

### IMPORTANT!

Only use this kit on towed vehicles with variable voltage lighting and incandescent bulbs.

If this vehicle has variable voltage lighting AND LED BULBS, use kit 153789 instead.

### What are variable voltage taillights?

These are taillights that use the same wire to power the brake lights and taillights. This is accomplished by using a 12-volt signal for brakes and a lower voltage signal for tail-lights.

### Why can't I use regular wiring diodes?

You can for standard lighting systems, but with variable voltage systems the RV will only supply 12-volts — causing the taillights to always look like the brakes are on.

### WARNING

Read the instructions before installing the kit components, and wire the towed vehicle according to the instructions and illustrations. Failure to understand how to install this product could result in an electrical malfunction or other collateral or consequential damage.



## Step A

### Identify the RV's lighting system

1. There are two types – combined or separate. In a **combined** system, the brake light does the flashing for the turn signal; in a **separate** system, there are amber or red turn signal lights which are separate from the brake lights.

If the motorhome has a separate lighting system, a 3-to-2 converter must be installed in order to use this kit. A 3-to-2 converter converts a separate system to a combined system.

Many late-model motorhomes come with converters already installed – test for this before installation: if the motorhome's trailer plug energizes the same pins for both brake lights and turn signals, then a 3-to-2 converter is already installed and the motorhome should be treated as combined.

## Step B

### Wire the towed vehicle for towing

1. Expose the wires behind both taillight assemblies. (It may be necessary to remove the taillight assemblies from the exterior of the vehicle to gain access).
2. With a circuit tester, identify the left brake wire.

### WARNING

Attach the diodes as close to the towed vehicle's lights as possible, to avoid interaction with other circuits which may be tied into the center brake light, the running lights, the turn signals or the brake light wires.

Attaching the diodes farther away may cause the towed vehicle's lights to work improperly, as well as cause damage to other electrical components in the vehicle.

3. Attach the Smart Diode to the left brake wire, as per Figure 1.

4. Identify the right brake wire and connect it to a Smart Diode, as per Figure 1.

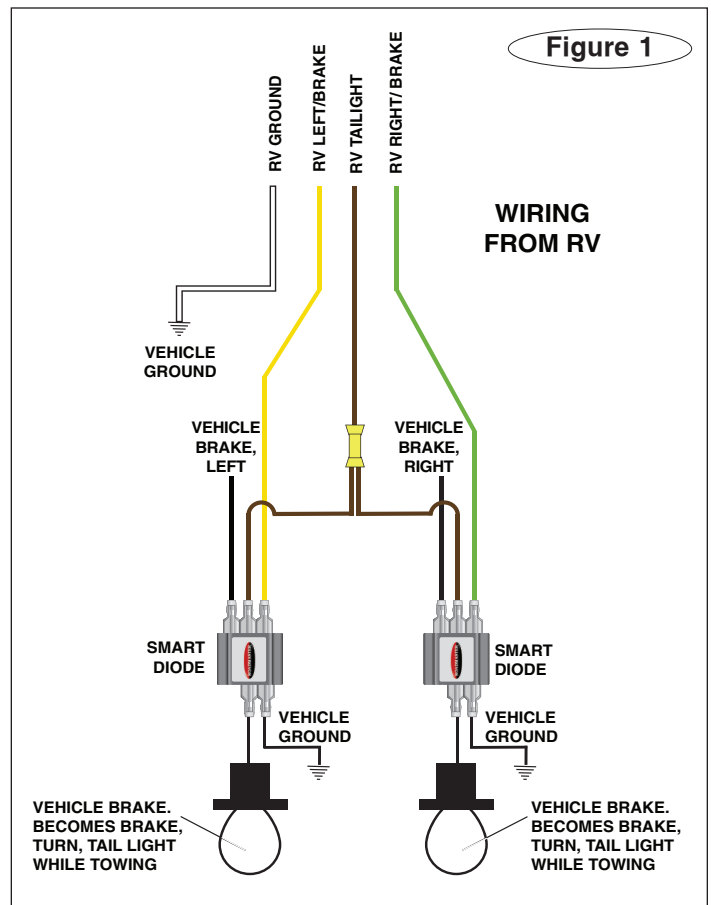

continued from preceding page

5. Now crimp the 12" white wire to the terminal labeled Ground and repeat for the other diode. Use the included ring terminals and Tek screws to ground both wires to the chassis.

*Note: To avoid grounding problems, attach the wire to a good chassis ground, preferably directly to the frame.*

### CAUTION

**Refer to the vehicle owner's manual before attaching the ground wire. Some manufacturers may stipulate that ground wires must be attached at specific locations.**

**Significant damage to the vehicle's electrical system, as well as other consequential, non-warranty damage will occur if the ground wire is not attached at one of these points.**

6. Following the schematic, separate the four bonded wires as necessary and connect each wire to the Smart Diodes as shown in Figure 1 (previous page). Use the included yellow butt connector to separate the RV taillight signal to each Smart Diode. Use a ring terminal to ground, as shown in Figure 1.

### CAUTION

**Failure to attach the diodes as indicated in the wiring diagrams will create a backfeed through the vehicle's electrical system, which will allow electrical current from the towed vehicle to disrupt one or both of the vehicles' electrical systems.**

**Additionally, if a supplemental braking system is installed it may not operate, or may only operate intermittently.**

### Step C

#### Route the wiring harness

1. Carefully route the 4-wire harness to the front of the vehicle. Before you begin, plan a route to the front of the vehicle that avoids the possibility of fraying or melting the wiring against moving parts, sharp edges, the fuel lines or hot components. (If the OEM wiring harness is accessible, consider routing the harness alongside it).



### WARNING

**Plan a route that will avoid moving parts, sharp edges, the fuel lines or hot components such as the engine or exhaust system.**

**Wiring exposed by moving parts, sharp edges or hot components may cause a short circuit, which can result in damage to the vehicle's electrical system as well as other, consequential damage.**

**Wiring which is attached in close proximity to the fuel lines may ignite the fuel.**

2. Where appropriate, use a section of the included split loom to protect the wires; use one or more of the included wire ties to secure the wiring in place.

3. If it was necessary to drill a hole, seal it with silicone sealant (not included) after you have routed the harness to the front.

### Step D

#### Attach the wiring harness

1. Attach the end of the 4-wire harness to the electrical socket (not included) at the front of the towed vehicle. Connect the wires according to the instructions that came with the electrical socket.

### Step E

#### Test the system

1. Test each of the circuits to confirm that the lighting functions correctly.

2. Operate the vehicle's brake, turn signals and taillights to verify the lighting system still functions correctly. *Note: The vehicle may need to be running to energize the circuits.*

## Troubleshooting Section

**Symptom:** The Smart Diodes are installed properly and there is current going into the Smart Diodes, but there is no current coming out.

**Solution:** In some vehicles, the lamp-out module stops the flow of current as it can detect the multiple paths to ground and assumes there is a fault. To correct this, disconnect the ground wire on just ONE of the Smart Diodes.

