

Hide-A-Goose

Part Numbers:
9488/9475

Installation Instructions

**Do Not Exceed Lower of Towing Vehicle
Manufacturer's Rating or**

**30,000 LB (13620 Kg) Max Gross Trailer Weight (GTW)
7,500 LB (3405 Kg) Max Tongue Weight (TW)**

Equipment Required:

Fastener Kit: 58320 and 58564

Wrenches: 15/16"

Drill Bits: 3/16", 5/8", 3 1/2" Hole Saw

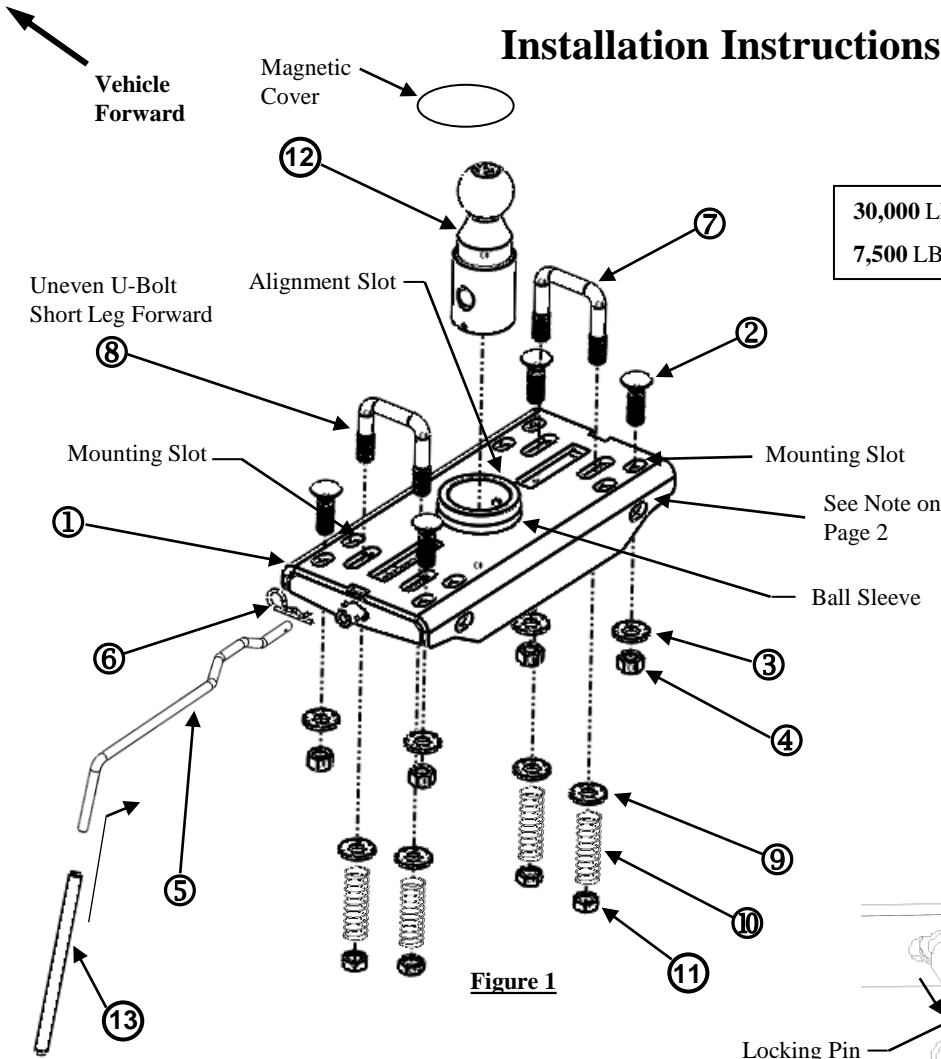

Figure 1

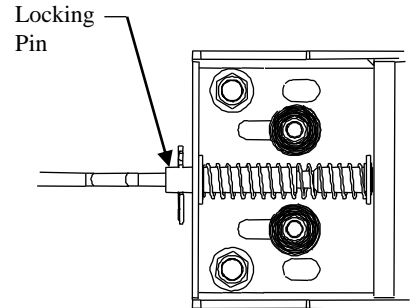

Figure 2

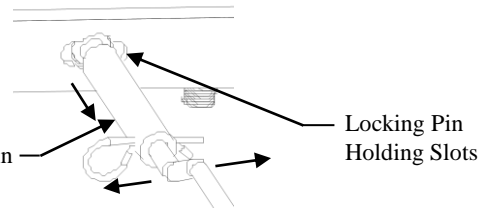

Figure 3

A brand label, *Draw-Tite*, is supplied with this hitch. After installing mounting kit to truck frame, peel and apply this label to surface of frame bracket.

IMPORTANT!

This product is intended to be used with Horizon Global manufactured mounting kits. If the Gooseneck hitch installation is made with Horizon Global manufactured mounting kits, the installation instructions for the Gooseneck hitch are included as part of the mounting kit installation instructions. Give this installation instruction to vehicle owner after installation is complete.

General instructions for fabricated support structures.

IF HORIZON GLOBAL MANUFACTURED MOUNTING KITS ARE NOT USED, THIS PRODUCT BECOMES A GENERAL APPLICATION PRODUCT. IT IS THE RESPONSIBILITY OF THE INSTALLER TO SELECT STRUCTURALLY SAFE MATERIALS AND LOCATIONS FOR ATTACHMENT. INSTALLATION INFORMATION FOLLOWS.

①	Qty. (1)	Head	⑧	Qty. (1)	5/8" Uneven U-Bolt, 2-1/2" and 3" Legs
②	Qty. (4)	5/8" -11 X 2.00 Grade 8 Carriage Bolt	⑨	Qty. (4)	Conical Toothed Washer
③	Qty. (4)	Conical Toothed Washer	⑩	Qty. (4)	U-Bolt Spring
④	Qty. (4)	5/8"-11 Hex Nut	⑪	Qty. (4)	5/8"-18 Lock Nut
⑤	Qty. (1)	Handle	⑫	Qty. (1)	2-5/16" Ball
⑥	Qty. (1)	Spring Clip	⑬	Qty. (1)	Vinyl Handle
⑦	Qty. (1)	5/8" U-Bolt, 3" Legs			

Tighten all 5/8 grade 8 fasteners (exclude U-bolt fasteners) with torque wrench to 210 Lb.-Ft. (285 N*M)

Note: check hitch frequently, making sure all fasteners and ball are properly tightened. If hitch is removed, plug all holes in trunk pan or other body panels to prevent entry of water and exhaust fumes. A hitch or ball which has been damaged should be removed and replaced. Observe safety precautions when working beneath a vehicle and wear eye protection. Do not cut access or attachment holes with a torch.

Installation Instructions

Part Numbers:
9488/9475

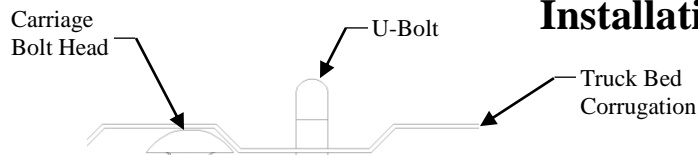

Figure 6

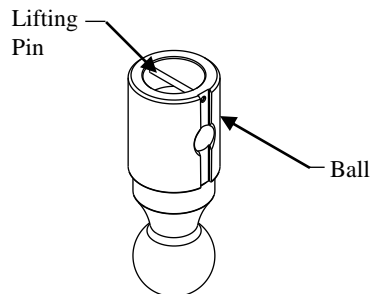

Figure 5

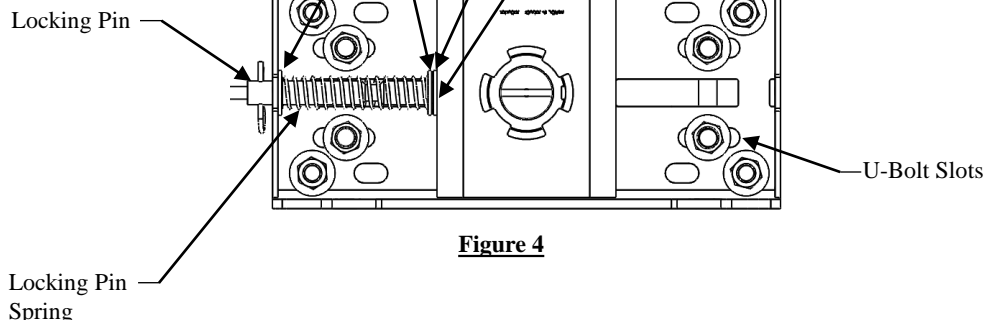

Figure 4

- The following guidelines must be followed before installation begins:
 - The hitch ball must be located along the truck's fore/aft centerline.
 - The hitch ball centerline must be located above and forward of the rear axle of the truck.
 - Adequate clearance must be provided between the gooseneck trailer and the rear of the vehicle so that the gooseneck trailer does not contact any part of the truck during turning.
 - Adequate clearance must be provided between the forward corners of the gooseneck trailer and the cab of the truck.
 - Determine that the ball position and under vehicle supports do not interfere with any vehicle cross members, brake lines, electrical wiring, cables, fuel lines or vents.
 - Install under bed supports with (4) vertical 5/8" bolts in rails.
 - With hitch ball center marked on the truck, center punch and drill 3/16" pilot hole, recheck all clearances, then open the 3/16" hole with a 3 1/2" hole saw. File edges as needed.
 - Lift head into position.
 - Use the 5/8" conical toothed washers and hex nuts to install the head. Do not tighten completely at this time.
 - Align ball sleeve on head, with the 3-1/2" hole in bed and tighten 5/8" fasteners.
 - Using the U-Bolt slots as a guide, drill four 5/8" holes in the bed. These holes must be in a lower bed corrugations to limit the amount of U-bolt showing above the bed (see figure 6).
 - Touch up the drilled holes with paint.
 - Install the U-Bolts from the inside of the bed (see figure 2).
- NOTE: On Chevy/GMC 2500/3500 trucks, install the U-Bolt with the uneven legs on the driver's side with the short leg forward to allow extra room for fuel tank and components.**
- From under the truck, install the conical toothed washers, U-Bolt springs, and 5/8" lock nuts (see figure 1 and 2). Before tightening lock nuts, lift U-bolts up and down to assure smooth operation. If not, then enlarge holes, as necessary. Tighten nuts so a minimum of 3 threads are showing passed the nuts.
 - With the ball in the stored position (see figure 5). Check for clearance between ball and truck equipment (I.E. differential, brake lines, electrical lines, and others) by measuring from axle up to rubber bumper stop and from ball to nearest item. If insufficient space is present, inform customer not to store ball in the head when carrying heavy loads. The axle to the rubber bumper stop distance should be less than the ball to nearest item.
- NOTE: If not installing head on Horizon Global manufactured mounting kit, secure the hitch to your mounting system using the four holes in the front and back of the hitch and four 5/8" (grade 8) bolts (not provided). See figure 1. This is in addition to the four vertical bolts provided in the kit and will allow you to obtain the maximum head rating of 30,000 lbs. GTW / 7,500 TW lb.**

AFTER SYSTEM INSTALLATION AND BEFORE TOWING:

Connect trailer to the tow vehicle following coupler manufacturer's operating instructions. The coupler must be adjusted to provide about 6" of clearance between the bottom of the trailer nose and the top of the pickup bed sides. Slowly back the trailer to a jackknifed position to the tow vehicle while checking to see there is adequate clearance between the gooseneck trailer and the rear of the vehicle. Also check to see there is adequate clearance between the forward corners of the gooseneck trailer and the cab of the truck. Slowly jackknife the truck and trailer in the opposite direction and check the clearances to the end of the truck and the cab.

GOOSENECK MAINTENANCE

Use magnetic cover to keep assembly free of dirt and debris. Lubricate hitch ball monthly or as needed with heavy grease. Lubricate ball tube with heavy grease when ball is installed and/or removed. Lubricate locking pin monthly or as needed with spray-on penetrating oil. Check bolt torque monthly. Check equipment before towing for worn or damaged parts. **REPLACE WORN OR DAMAGED PARTS IMMEDIATELY.**